

Modifications are made to these books from time to time and it is important therefore that only the book sent with the machine should be used as a working manual

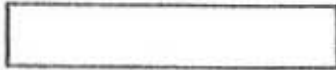

PLEASE INSERT SERIAL NUMBER OF MACHINE

PBR

Power Band Rip Saw

SPECIFICATION

Diameter of saw wheels	700mm	27.5in
Maximum depth under saw guide	489mm	19in
Maximum depth of cut	300mm	12in
Maximum distance saw to body	680mm	26.7in
Minimum width of blade	3mm	$\frac{1}{8}$ in
Maximum width of blade	65mm	2 $\frac{1}{2}$ in
Maximum length of blade	5080mm	16ft8in
Minimum length of blade	4910mm	16ft2 $\frac{1}{2}$ in
Speed of motor. 50Hz	3000rev/min	3000rev/min
Speed of motor. 60Hz	3600rev/min	3600rev/min
Power of motor	7.5KW	10Hp
Speed of saw blade	1500M/min	5000ft/min
Eight feed speeds	2-29M/min	6-98ft/min
Size of table	765x1000mm	30x39in
Height of table	900mm	35in
Floor space (No pit required)	800x1600mm	31 $\frac{1}{2}$ x63in
Weight (Approximately)	605kg	1331lb
Table cants with feed unit	25°	25°
Table cants without feed unit	35°	35°

OPTIONAL EXTRAS.

AUTOMATIC STAR DELTA STARTER.
FINE ADJUSTMENT TO TABLE CANTING
BY SCREW AND HANDWHEEL.
ELECTRIC INTERLOCK ON FOOT BRAKE.
SPOT LIGHTING EQUIPMENT.
INFEED AND OUTFEED ROLLER TABLES.

FOR REPLACEMENT PARTS, TOOLS AND ACCESSORIES,
CONTACT:- WADKIN CLEVELAND (Div Of Wadkin Ltd)
NORTH LIVERTON IND EST
LOFTUS
SALTBURN-BY-THE-SEA
CLEVELAND
ENGLAND
(Telephone: Guisborough 0287/40177)

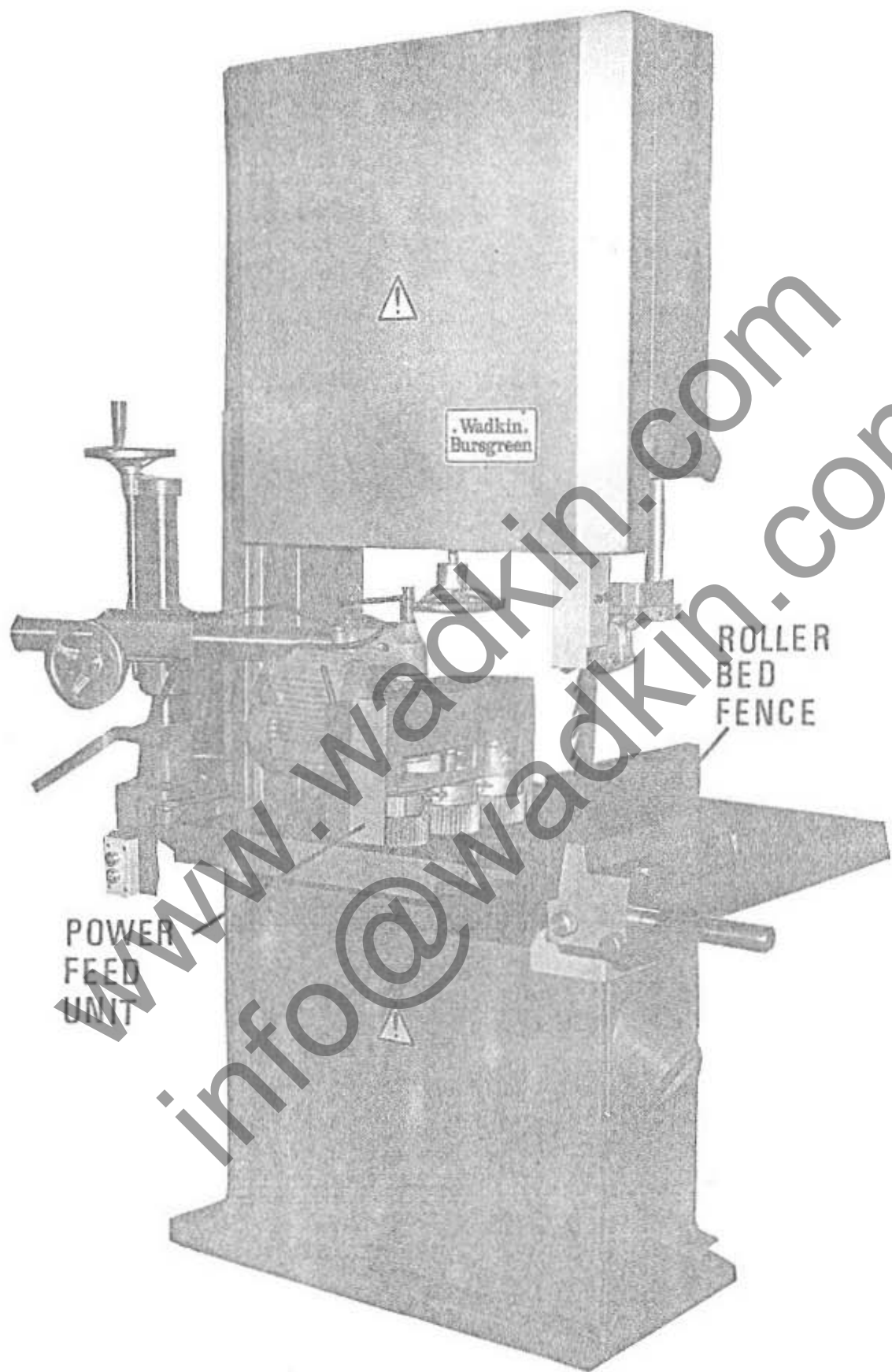

NOTE:- THIS BOOK TO BE USED IN CONJUNCTION WITH THE "C" RANGE BANDSAW AND AUTOMATIC FEEDER INSTRUCTION BOOK AND ALL INSTRUCTION BOOKS SHOULD BE READ BEFORE USING THE MACHINE.

FOR OPTIMUM BLADE LIFE THE FOLLOWING FEED SPEEDS ARE RECOMMENDED.

DEPTH OF CUT	1"	2"	3"	4"	6"	8"	10"	12"	
SOFT WOOD	98	49	39	33	20	16	13	6	FT/MIN
HARD WOOD	33	20	16	13	6	--	--	--	FT/MIN

MACHINE MUST BE BOLTED DOWN.

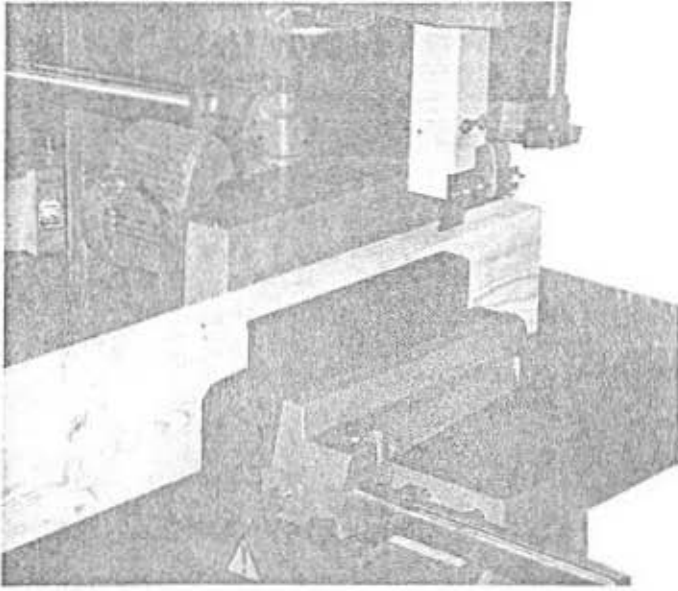

FIG 1

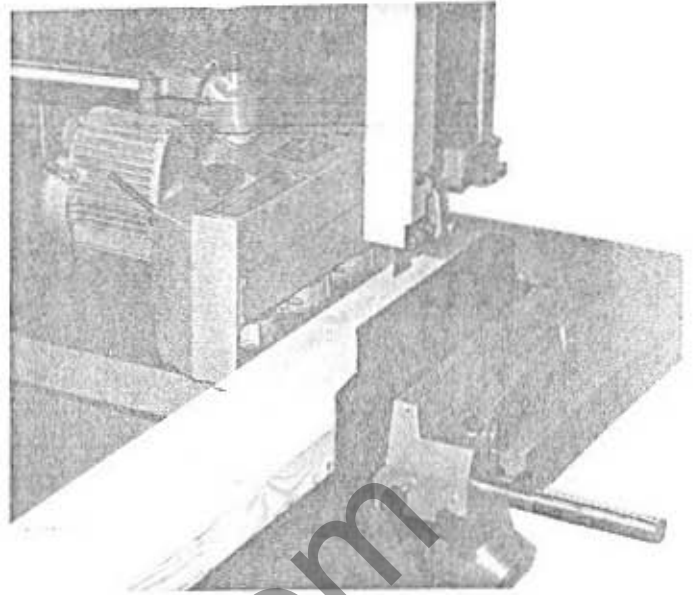

FIG 2

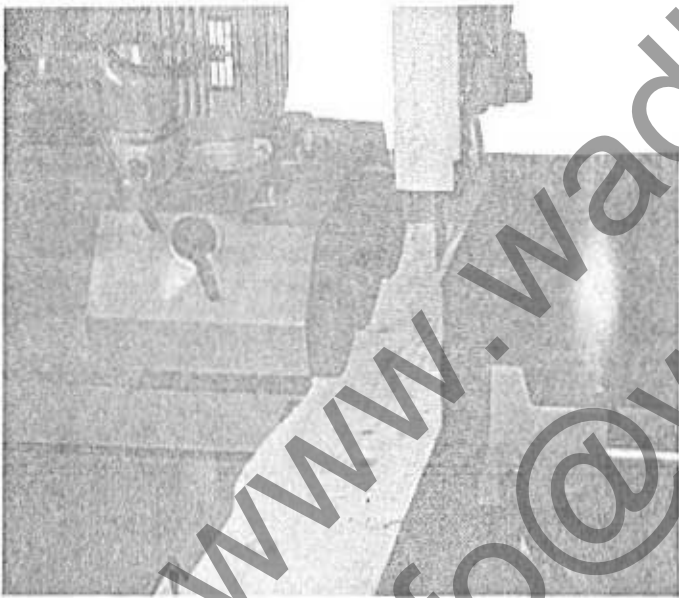

FIG 3

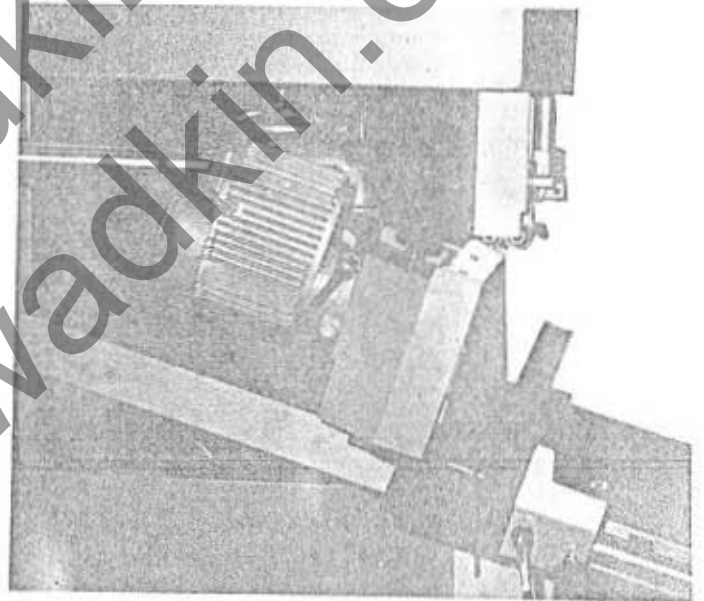

FIG 4

NOTE:- Figures 1-4 show the position the Feed Unit can be set to accommodate various stock sizes,

NOTE:- The Top Guide should always be set close as possible to the stock.

- FIG. 5. Top Saw Guide (See Setting Instructions)
- FIG. 6. Bottom Saw Guide (See Setting Instructions)
- FIG. 7. Tension Indicator
- FIG. 8. Tracking Saw Blade
- FIG. 9. Top Door Open To Allow Removal Of Blade
- FIG.10. Feed Unit Locks And Adjustment

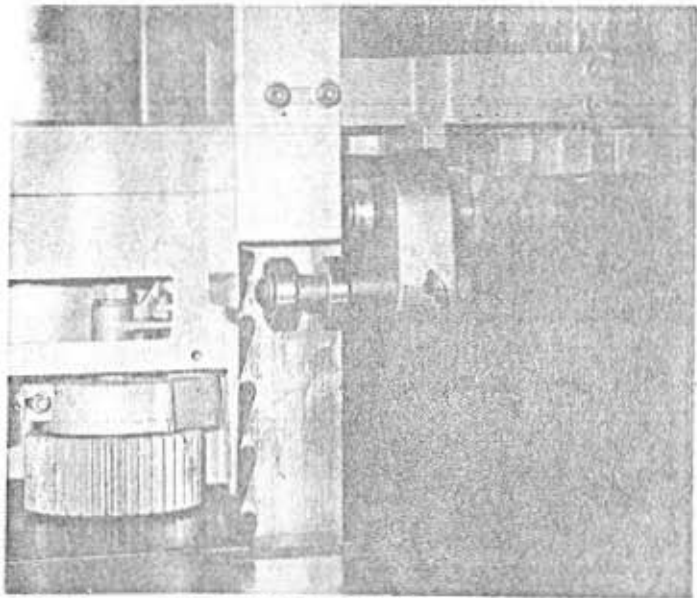
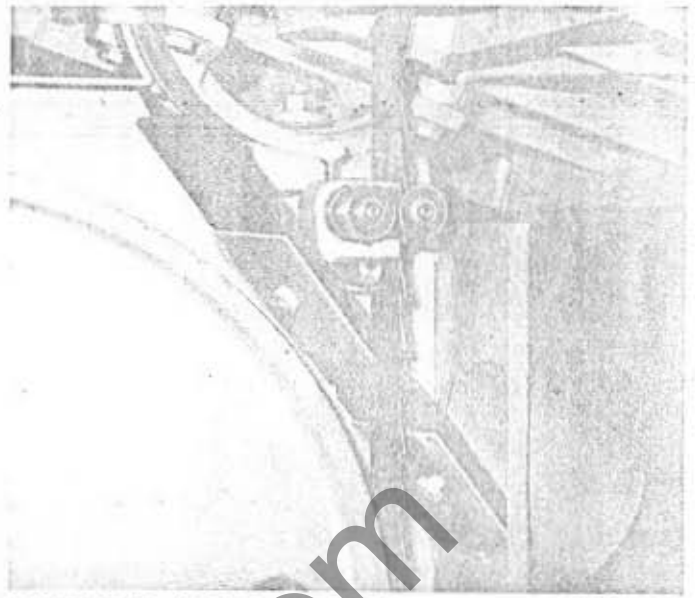

FIG 5 TOP SAW GUIDE



BOTTOM SAW GUIDE FIG 6

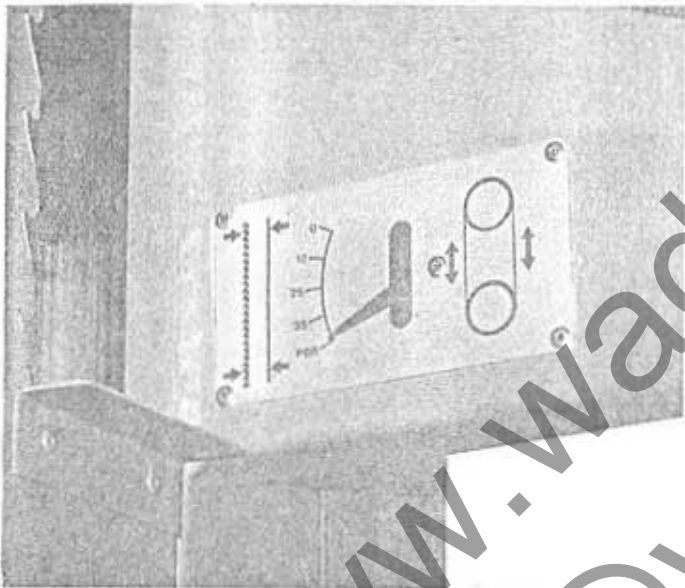

FIG 7 TENSION INDICATOR



POSITIONING OF SAW BLADE FIG 8



FIG 9

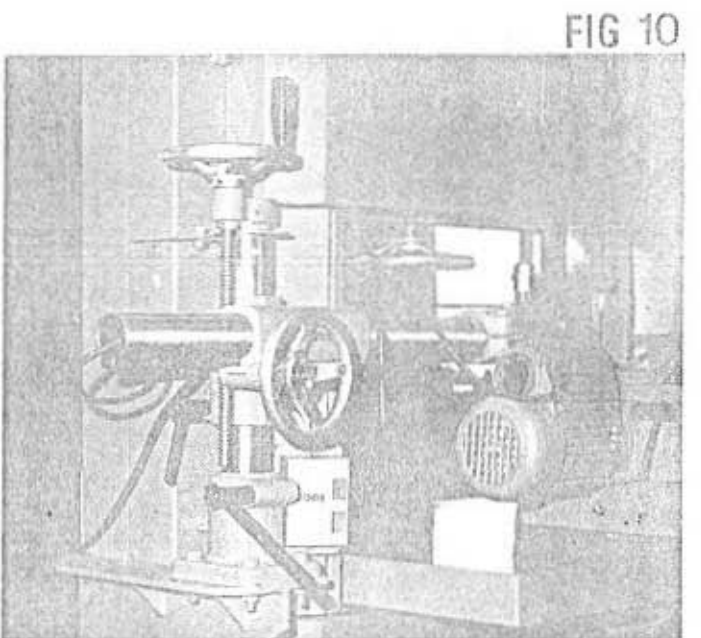

FIG 10

www.wadkin.com
info@wadkin.com

FITTING OF RIP SAW BLADES. (See also page 10 - "C" Range instruction book.)

- 1) Isolate machine electrically.
 - 2) Swing power feed unit out and open top door together until door clears blade guard aperture on main column of machine.
 - 3) Traverse roller bed fence to the right hand side of machine until it clears saw slot in table, open bottom door and remove top saw guard.
 - 4) Adjust top wheel sufficient to allow blade to be fitted to both wheels, tension saw blade until pointer on tension indicator (See fig 7, page 9.) indicates P.B.R.
 - 5) Tracking of the saw blade is done by rotating the top wheel slowly by hand in a clockwise direction, the root of the saw tooth should overhang the rim of the wheel by approximately 2mm (see fig's 8 & 12).
- Should blade not track correctly, loosen wing nut "B", fig 11 then turn handwheel "C" until saw is tracking correctly then tighten wingnut "B".

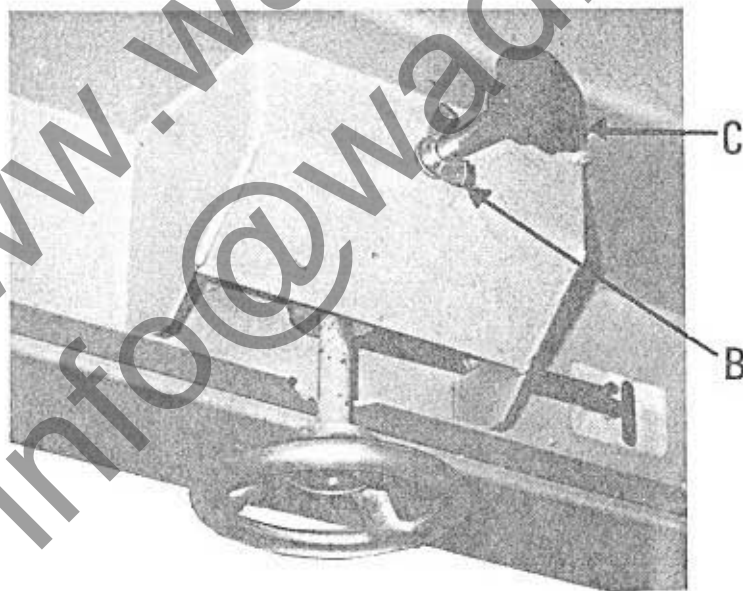
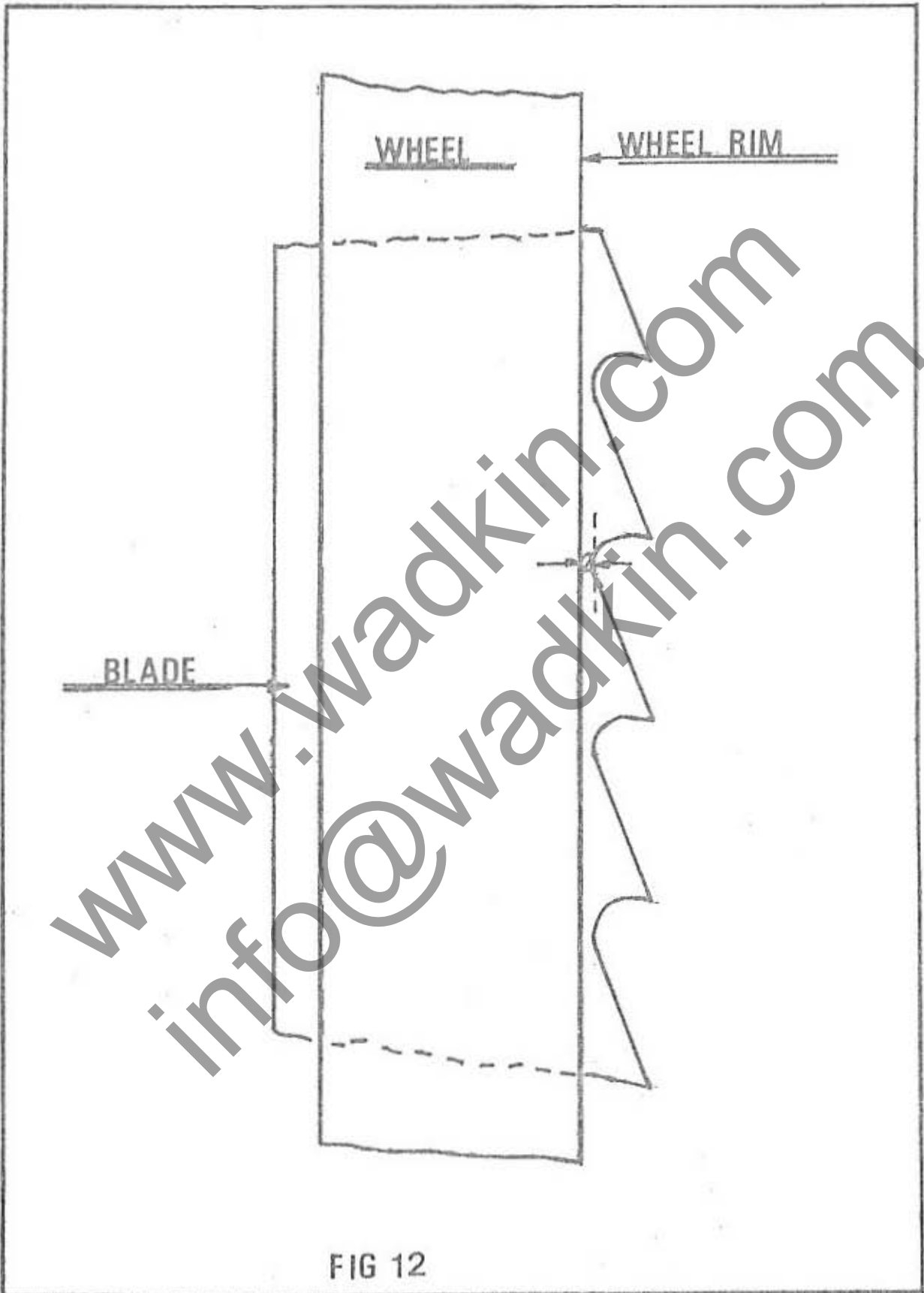

FIG 11



SETTING SAW GUIDES

The top and bottom guide units Fig 5 & 6 should be set up as follows with the top saw guide as close to the stock as practical.

- 1) Loosen grub screw "A" and M10 "B" Fig 13. then position guide body "C" central and parallel to blade see Fig 14, then tighten up grub screw "A" and M10 Nut "B".

NOTE:- Once the guide bracket has been intially set up, only the adjustment described in paragraphs 2 & 3 should be necessary.

- 2) Slacken thumb screw "Y" Fig 13, and set near guide roller approximately 5mm clear of back of blade (See Fig 15) and lock up thumb screw securely.
- 3) Slacken thumb screws "X" Fig 13, and move side guide rollers forward as positioned in Fig 15, then pivot side guide rollers on anti lock eccentrics until they are just clear of blade and lock thumbscrew "X".

NOTE:- It is important to check that the side guide rollers do not nip the blade when locked up, and that the guide assembly is square to the natural line of the blade (see Fig 16).

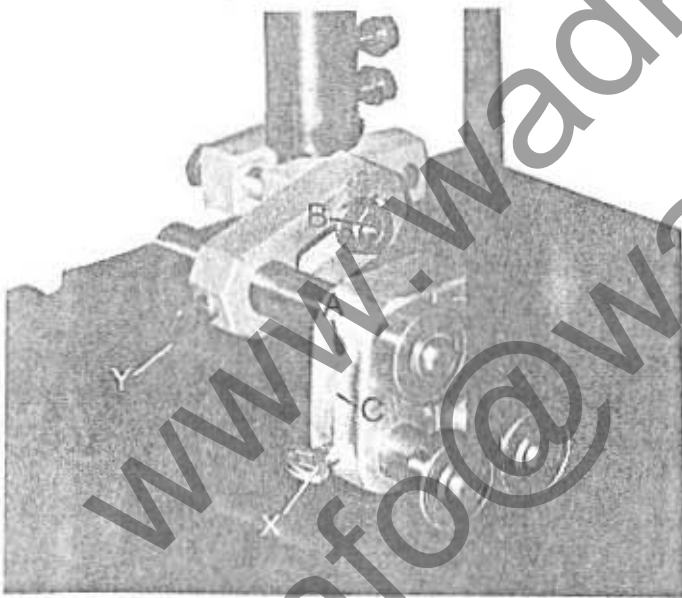

FIG 13

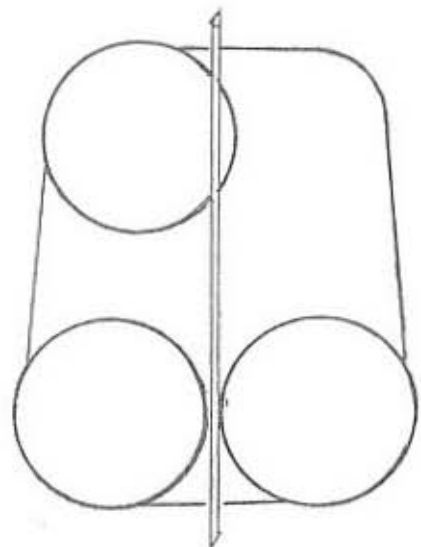
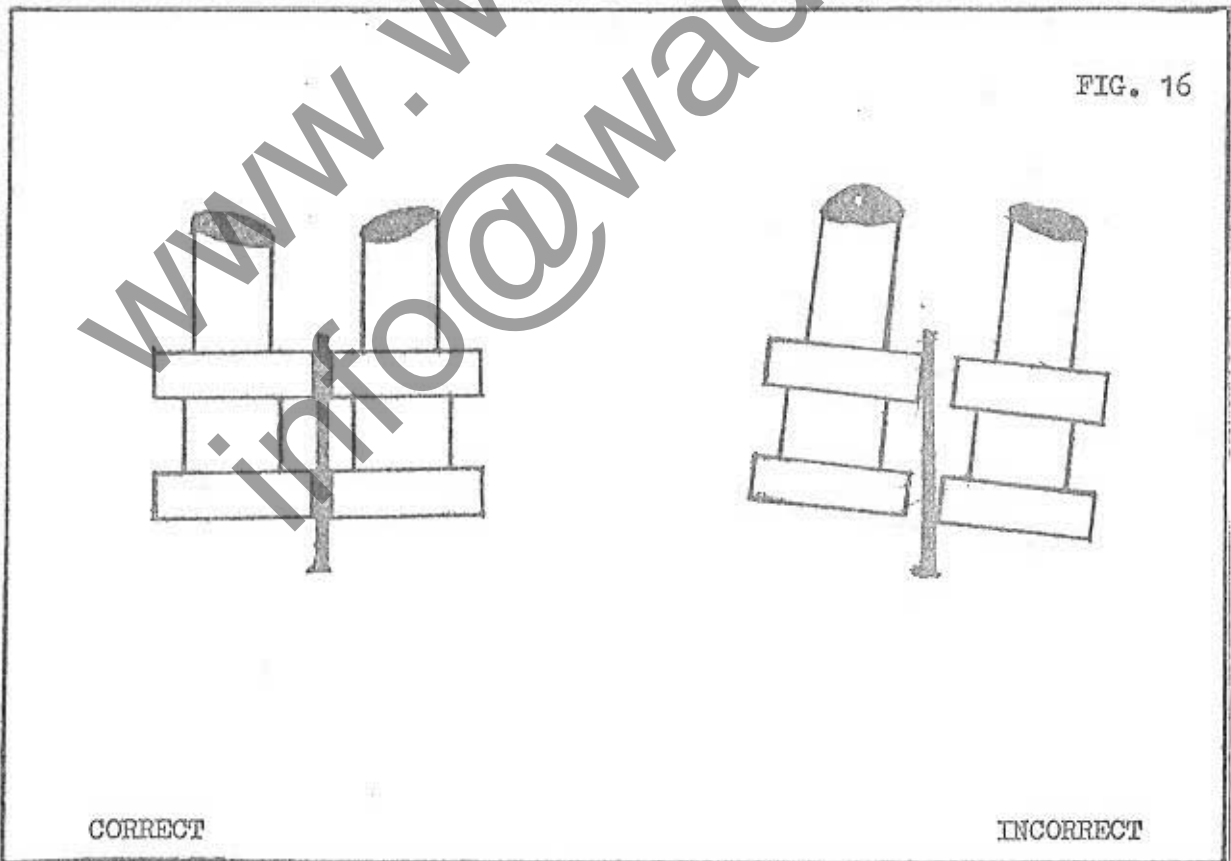
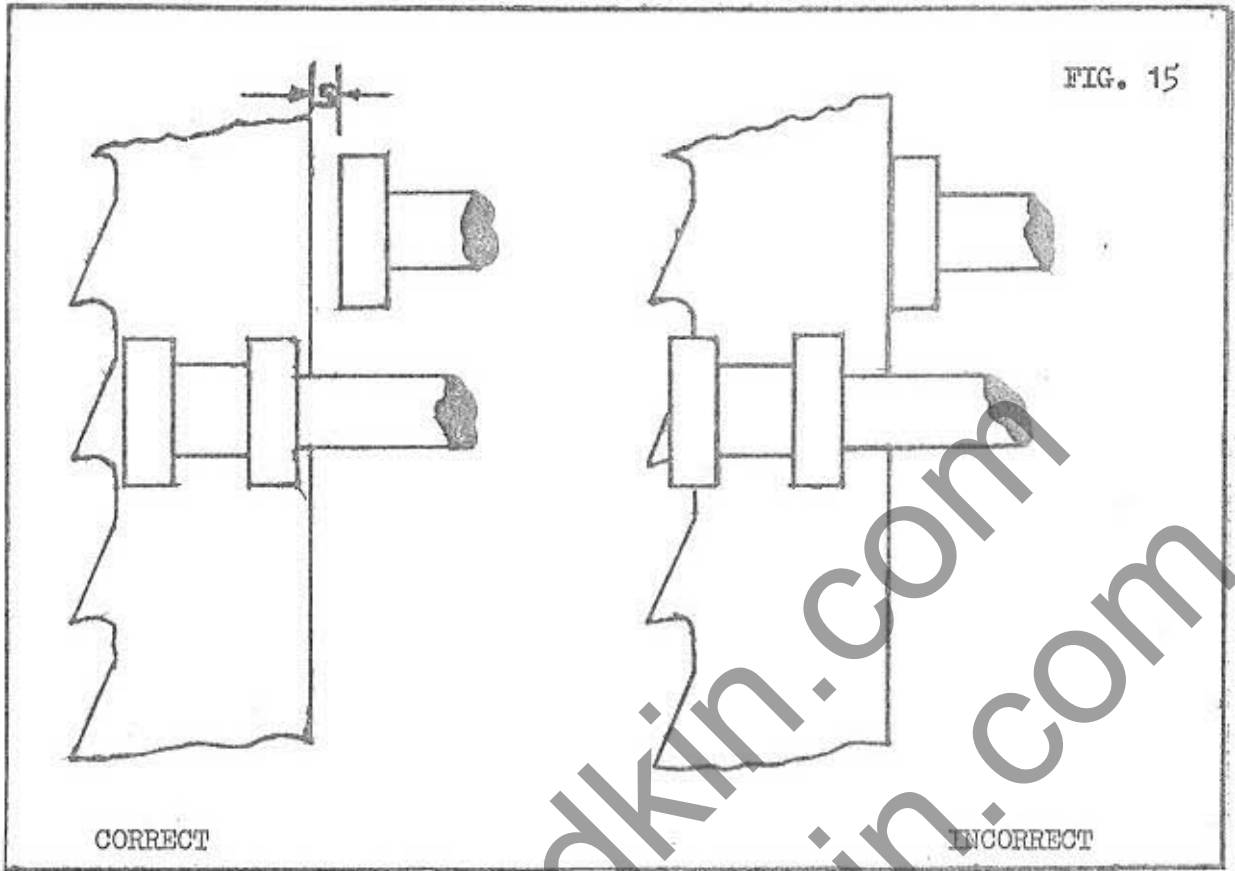

FIG 14



FEEDER UNIT. Fig 17.

The feeder unit can operate in both directions and has 8 speeds attained by:-

- A) Two speed motor with switch positions 1 and 2.
- B) Gear lever with positions I and II.
- C) Inter changing gears Nos 44 and 65.

The feeder unit should always be operated in accordance with the instructions supplied.

Best feeding results are obtained when face of feed rollers are parrallel to timber.

IMPORTANT. All locking points (Fig 18) must be secured before feeding, otherwise unit may pull itself into blade.

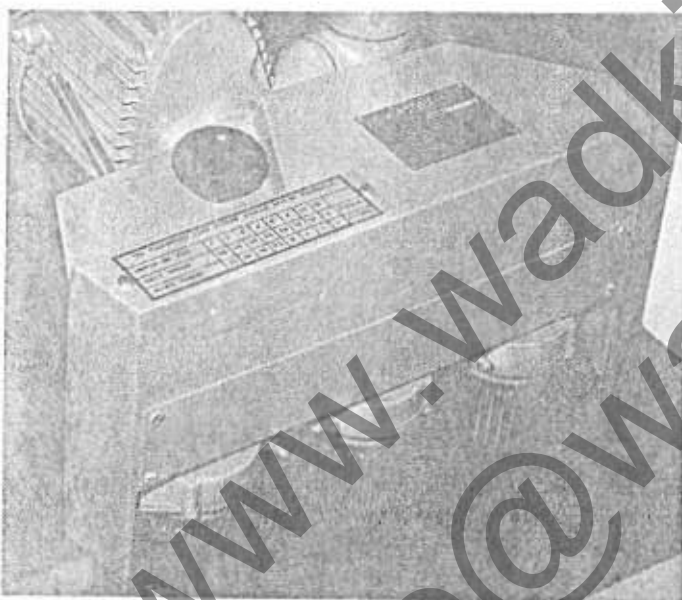

FIG 17

NOTE:- Feeder will not operate unless machine is running.

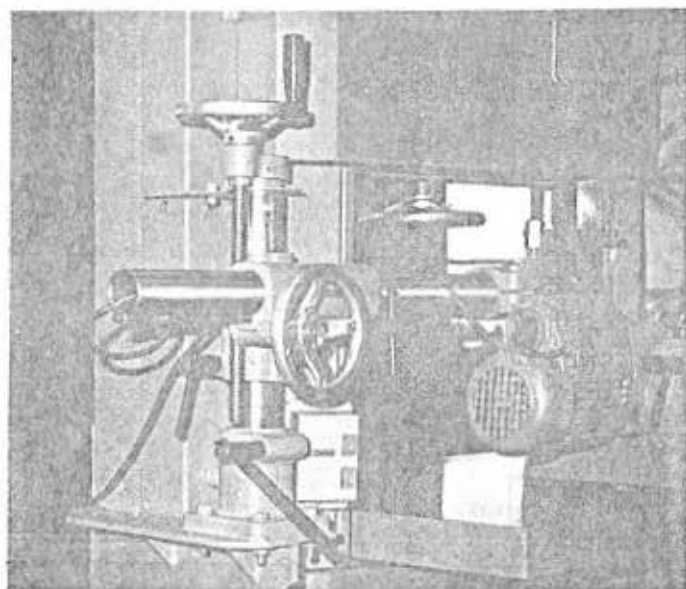

FIG 18

ROLLER BED FENCE.

The roller bed fence incorporates an adjustable pointer and fine adjustment mechanism, together with secure fence lock for accurate stock control. (see fig. 19).

The infeed bracket (fig. 19) on the fence incorporates a feeder setting scale (fig. 20) which is used as follows:-

- 1) Set fence to finished stock size desired.
- 2) Measure average width of stock to be ripped i.e. 100mm.
- 3) Align face of feed rollers to width indicated on feeder setting scale i.e. 100mm.

This setting method automatically gives 5mm motoring over pressure, and allows the unit to accommodate approximately 8mm stock variance without continual adjustment of feeder unit.

FIG 19

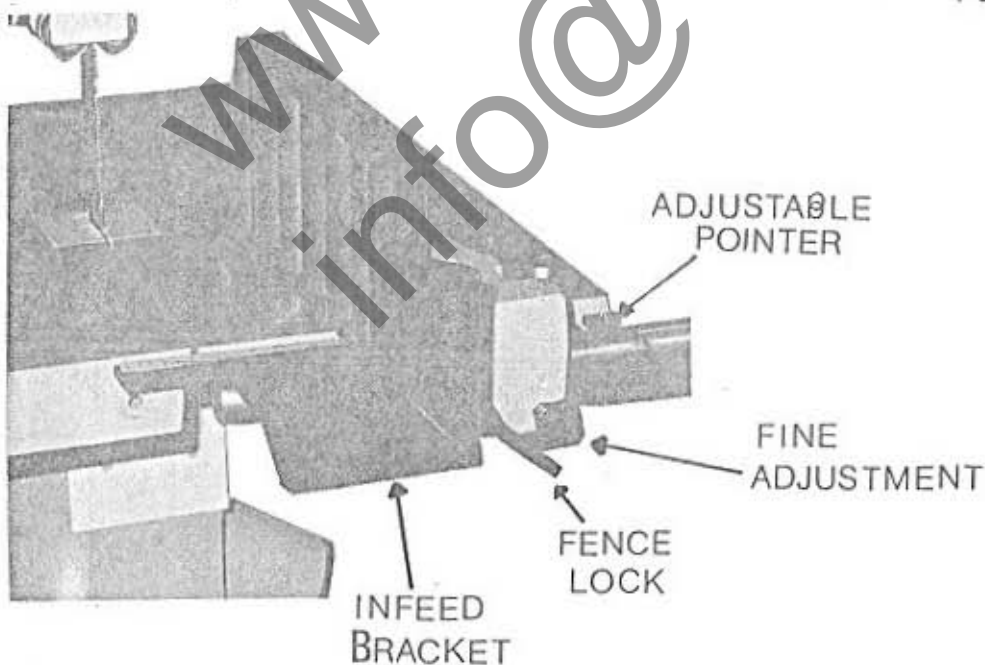

FIG 20

FEEDER SETTING
SCALE

GENERAL

All machines are fully tested before leaving our works, and are not passed unless in perfect working order.

They are simple to operate but nevertheless care is necessary in their use and the following instructions carried out.

- 1) Machines should be bolted down.
- 2) The machine should be connected to an efficient extraction system.
- 3) The machine should be kept clean and checked daily.
- 4) The bandsaw blades should be regularly maintained, cutting life will depend on depth and type of timber being cut.
- 5) The recommended feed speeds should not be exceeded.
- 6) Guide should always be set up correctly (see guide setting instructions).
- 7) Blade should always be tensioned and tracked correctly. (see blade fitting instructions).
- 8) All instruction books should be read fully before operating machine.
- 9) Always isolate machine electrically before carrying out any adjustments or maintenance.